

R & R Machine Works Inc.

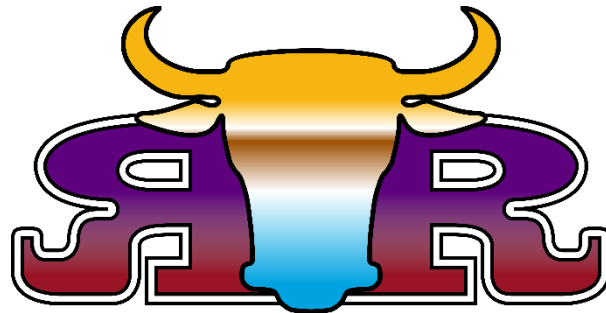

We really appreciate you making this purchase from us and we hope the equipment meets your expectations. We strive to sell equipment that will make your business as well as ours, prosper. When you have future equipment or service needs please think of us first!

If we can be of further services to you or your company,
please call us at (806) 244-5686.

Sincerely,

Owners and Management
Dalhart R&R Machine Works, Inc.

Table of Contents

Introduction	1
Safety	2
Installation	4
Tips on Operating your Mill	5
Adjustments.....	6
To Set Feed Rate	6
To Set Roll Clearance	7
How to Start your Mill.....	8
PARTS GUIDE – 12 X 52 Cracker Mill.....	9
12 inch Cracker Eccentric Assembly.....	9
Bearing Assembly List	10
Drive Sheave, Hub and Belt Assembly	11
Idler Belt Assembly	12
Roll and Cabinet Assembly.....	14
Agitator Feeder Cabinet Assembly	15
Magnet Cabinet Assembly	16
Limited Warranty	17

Introduction

Your new cracker is a quality mill that will give you many years of low cost operation if given the proper amount of care and maintenance.

Your mill has been engineered and designed with simplicity of operation in mind, but first and foremost to give the best quality product at maximum operating capacity.

Your cracker manufacturer stands ready to serve you at any time with service, whether it is in the form of maintenance and operating instructions, or on location with help performed by a qualified factory representative.

Your cracker manufacturer has, on hand at all times, any replacement part for your mill that you will need, and a supply of rolls corrugated and journaled to fit your mill and your operation.



Safety

Remember, YOU are the key to safety. Good safety practices not only protect you, but also the people around you. Make these practices a working part of your safety program. Be certain that everyone operating this equipment is familiar with the recommended operating and maintenance procedures and follows all the safety precautions. Most accidents can be prevented. Do not risk injury or death by ignoring good safety practices.

OPERATING SAFETY

1. Read and understand the Operator's Manual and all safety signs before using.
 2. Before servicing, adjusting, repairing, or maintaining unit, ensure that unit power source is completely shut down, and cannot start-up (locked out).
 3. Do not operate when any guards are damaged or removed. Install and secure guards before starting.
 4. Keep hands, feet, clothing, and hair away from all moving and/or rotating parts.
 5. Wear appropriate ear protection when operating for long periods of time.
 6. Review safety items with all personnel routinely.
- **DO NOT** modify the equipment in any way. Unauthorized modification will affect the warranty and may impair the function and / or safety and could affect the life of the equipment.
 - **DO NOT** make any adjustments or repairs on the equipment while the machine is running.

SIGNAL WORDS:

Note the use of the signal words DANGER, WARNING, and CAUTION with the safety messages. The appropriate signal word for each message has been selected using the following guidelines:

DANGER - Indicates an imminently hazardous situation that, if not avoided, will result in death or serious injury. This signal word is to be limited to the most extreme situations, typically for machine components that, for functional purposes, cannot be guarded.

WARNING - Indicates a potentially hazardous situation that, if not avoided, could result in death or serious injury and includes hazards that are exposed when guards are removed. It may be also used to alert against unsafe practices.

CAUTION - Indicates a potentially hazardous situation that, if not avoided, may result in minor or moderate injury. It may be also used to alert against unsafe practices.





**KEEP HANDS CLEAR
WHEN
EQUIPMENT
IS RUNNING**



**NO ACERQUE
LAS MANOS
CUANDO EL EQUIPO
ESTE FUNCIONANDO**



CAUTION

**DO NOT OPERATE
THIS MACHINE
WITHOUT GUARDS
IN PLACE**

PRECAUCION

**NO MANEJE
ESTA MÁQUINA
SIN GUARDIAS
EN POSICIÓN**



**LOCK-OUT
BEFORE WORKING
ON EQUIPMENT**



**CERRAR CON LLAVE
ANTES DE TRABAJAR
EN EL EQUIPO**

SAFETY SIGN REPLACEMENT

1. Keep safety signs clean and legible always.
2. Replace safety signs that are missing or have become illegible.
3. Replaced parts that displayed a safety sign should also display the current sign.
4. Safety signs are available from R and R Machine.

Installation

The installation of your cracker mill should be carefully planned and well engineered.

The following points should be followed to get the most out of your mill, both in capacity and quality:

1. There should be sufficient space around the machine for adjustments, repairs, and removal of rolls for recorrugation.
2. The mill should be installed on a level surface capable of withstanding the weight of the mill.
3. If the surface is not level, shims or grout should be used to avoid warping or binding the frame.
4. Install motor and drive as recommended by the factory. If the motor base or rails are not mounted, the motor must be fastened securely and the V-Belts aligned with the available space to tighten belts at a later time.
5. Provisions should be made to adequately feed the Mill.
6. Provisions must be adequate to take the product from the Mill. This is usually done by any of several methods.
7. Rolls must be kept in TRAM at all times. It is especially important when rolls are changed.



Tips on Operating your Mill

R&R Machine Works Mills are designed to efficiently produce a high quality of commercial grade product.

The capacity of your mill will be dependent on the following conditions either singly or in combination.

1. Size of product
2. Toughness or Friableness of product
3. Friable-easily crumbled or pulverized
4. Moisture content
5. Amount of conditioning
6. Size of desire product
7. Foreign material present
8. Corrugation on rolls

The capacity can be increased somewhat if the quality of the final product is not critical.

The rolls are usually set further apart when grinding larger size particles. It may be necessary to adjust the spring tension to obtain your desired final product. This adjustment is explained in this manual.

As the corrugation begins to wear off, you will not notice the decrease in capacity at first, but as the corrugation becomes duller, the capacity will be greatly reduced from the original corrugation. Also, it will be hard to meet grind specs. When this occurs, the rolls should be re-corrugated.

NOTE: Be careful when making adjustments. Do not allow the rolls to run together. This will cause the corrugation to become dull very rapidly.

Adjustments

Your R&R Machine Works Mill was shipped assembled and adjusted, but to meet your requirements, certain re-adjustments may be made as necessary to control rate of production and quality of product.

The following section will aid you with these adjustments to meet your requirements.

To Set Feed Rate

CAUTION: CARE SHOULD BE TAKEN TO KEEP FINGERS AWAY FROM MOVING PARTS.

To increase feed rate:

1. Release lock and move feed gate upward to desire feed rate and set lock.

To decrease feed rate:

1. Release lock and move feed gate downward to desired feed rate. Reset lock.



To Set Roll Clearance

Refer to Drawing A:

1. Assure power to the mill is shut off.
2. Pull adjustment handle #1 down until rolls come together. This clearance has been preset upon leaving factory at .016".
3. Place feeder gauge of desired clearance between rolls. Loosen jam nuts #4 and #8. Adjust nut #5 according to gauge-turn toward swivel housing #3 to increase roll clearance; turn away from housing #3 to decrease roll clearance.
4. Adjust nut #7 equal to nut #5 to retain spring tension. Normally the spring preload (difference in spring free length and compressed length) should never be greater than one inch. If more spring tension is needed to maintain product consistency, tighten nut #7 towards housing #3 until desired product is achieved. Tighten jam nut #8 up against nut #7.

Note: Be sure to adjust nuts equal amounts on each side of machine.

5. When desire setting is obtained; tighten jam nuts, #4 and #8 to lock roll setting.

Desire settings for each type of grain will be determined by experimentation depending on conditions.

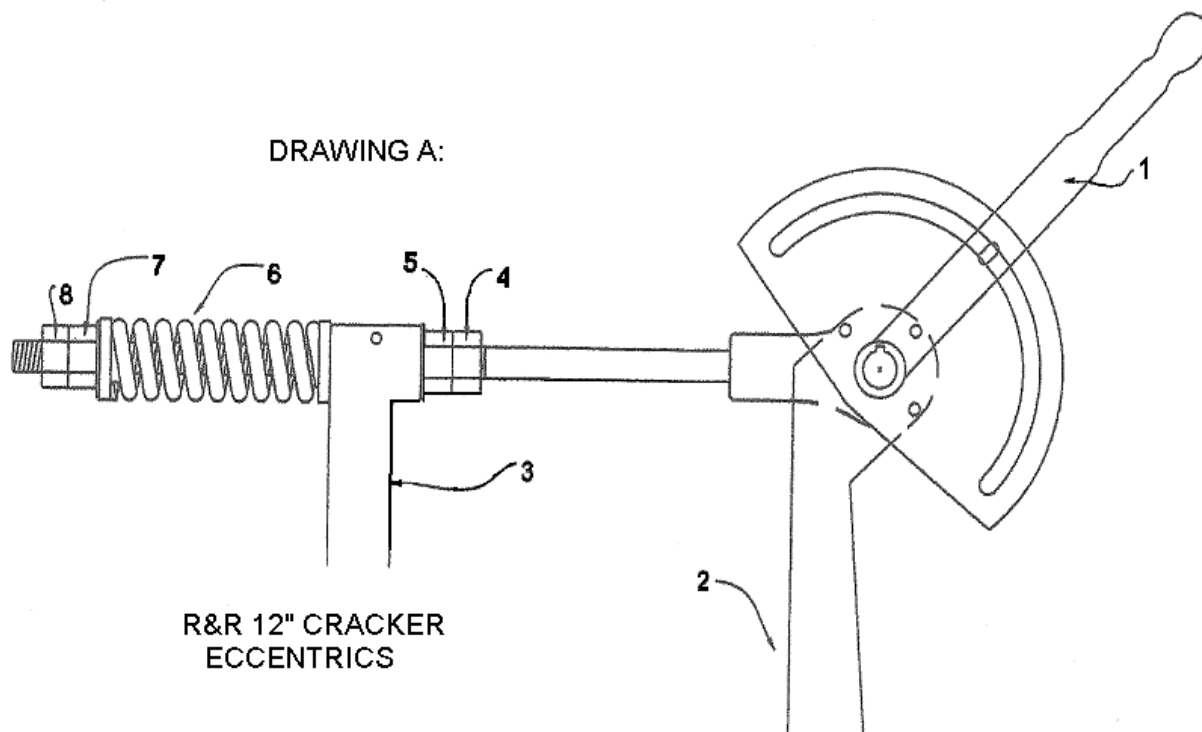

How to Start your Mill

BEFORE STARTING:

1. Check feed control gate – it should be closed.
2. Move roll adjustment to open position (this moves rolls apart).

TO START MILL:

1. Start motor.
2. Move roll adjustment to closed position (this moves rolls together).
3. When mill comes up to speed, adjust feed rate to desired amount.

TO STOP MILL:

1. Shut feed off above mill.
2. Close feed gate.
3. Open rolls – move roll adjustment to open position.
4. Stop motor.



PARTS GUIDE – 12 X 52 Cracker Mill

12 inch Cracker Eccentric Assembly

ITEM	ITEM #	PART DESCRIPTION	ITEM	ITEM #	PART DESCRIPTION
1	ECC0012A	ECCENTRIC CONNECTING	19	WF114	1-1/4 FLAT WASHER
2	ECC0818	CONNECTING SHAFT	20	N114CT	1-1/4 NUT
3	ECC0518	ECC. LONG SHAFT	21	BOL38X3	3/8 X 3 BOLT
3A	ECC0418	ECC. SHORT SHAFT	22	N38CT	3/8 NUT
4	ECC0312	ECCENTRIC HOUSING	23	KY38	3/8 X 1 KEY
5	ECC0712	ECCENTRIC TENSION ROD	24	WL716	7/16 LOCKWASHER
6	ECC08SPW	SPRING WASHER	25	N716CT	7/16 NUT
7	ECC08SP7	TENSION SPRING	26	BOL716X312	7/16 X 3-1/2 BOLT
8	BOL38X1	3/8 X1 BOLT	27	GRSZK	1/8 GREASE ZERK
9	ECC0012B	BRACKET	28	HSGR5	STATIONARY HOUSING
10	ECC0012L	LEVER	29	HSGR6A	SWIVEL HOUSING
11	ECC0012BS	T BOLT	30	N58CT	5/8 NUT
12	ECC0012BSL	WING NUT	31	WL58	5/8 LOCKWASHER
13	WL38	3/8 LOCKWASHER	32	WF58	5/8 FLATWASHER
14	BOL38X1ST	3/8 X1" SET SCREW	33	BOL58X212	5/8 X 2 1/2 BOLT
15	ECC0218	ECCENTRIC	34	ECC08SPB	12" SPRING PIVOT PAD
18	BOL38X312	3/8 X 3-1/2 BOLT	35	ECC0012S	OPEN/CLOSE STICKER

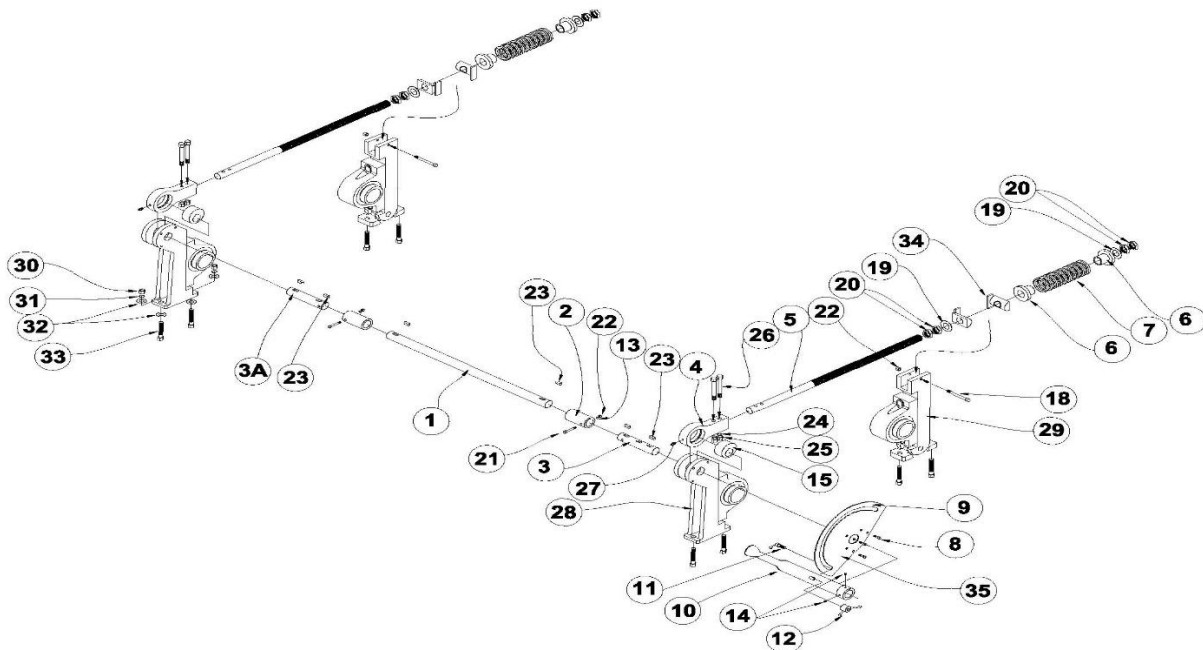

Bearing Assembly List

ITEM	ITEM #	PART DESCRIPTION
1	R1252R	12 X 52 FOLLOW ROLL W/JOURNALS
2	R1252DR	12 X 52 DRIVE ROLL W/JOURNALS
3	DS12x38	3/8 FELT
4	N58CT	5/8 NUT
5	WL58	5/8 LOCK WASHER
6	WF58	5/8 FLAT WASHER
7	HSGR5	STATIONARY BEARING ARM
8	BRGZA6215ND	2-15/16 PILLOW BLOCK BEARING
9	BOL58X4	5/8 X 4" BOLT
10	HSGR6	SWIVEL BEARING ARM
11	HSGR7	SWIVEL ARM BASE
12	DS8X8	8 x 8 x 1/8 POLY DUST SHIELD

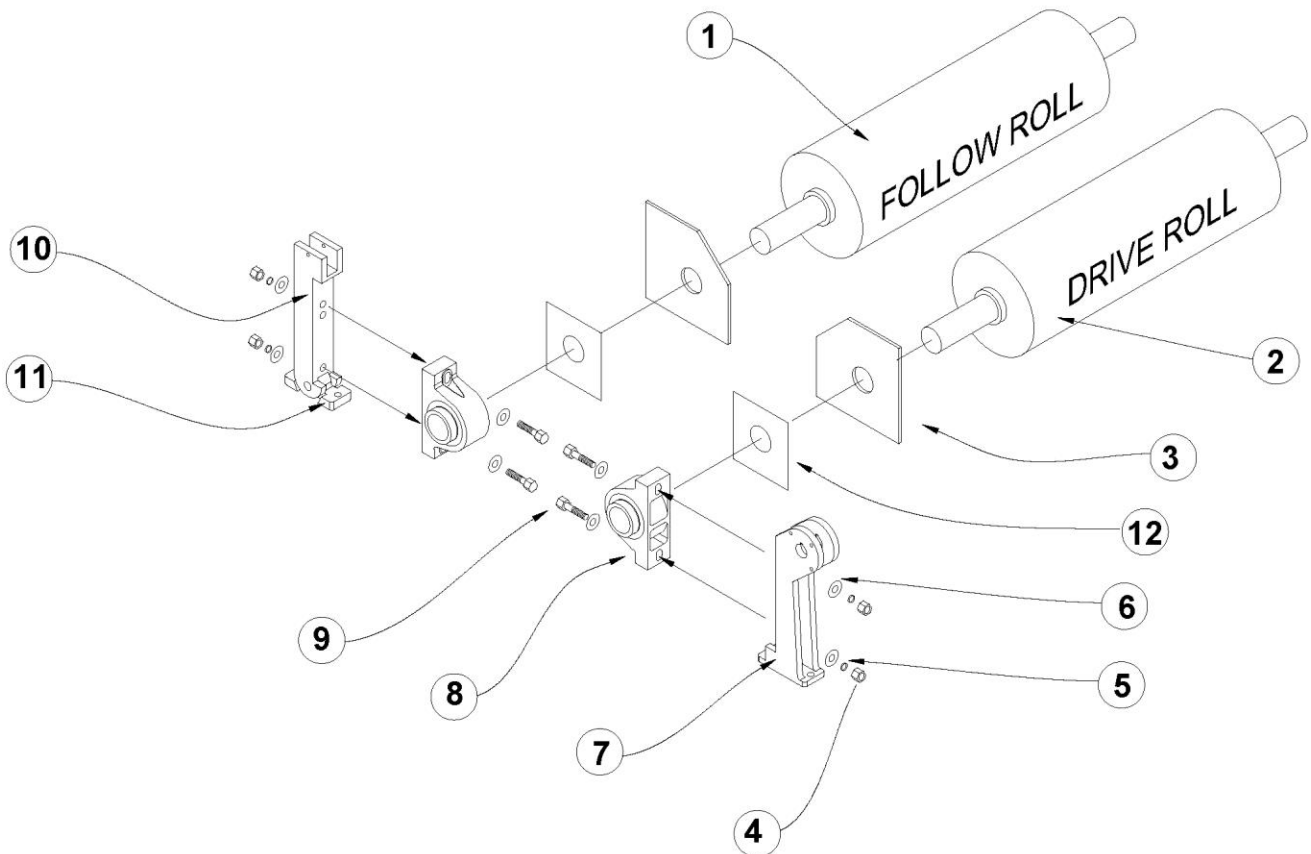

Drive Sheave, Hub and Belt Assembly

ITEM	ITEM #	PART DESCRIPTION	ITEM	ITEM #	PART DESCRIPTION
1	KY58	5/8 KEYSTOCK	11	HBF21516	F 2 15/16 HUB
2	HBE218	2 1/8 HUB	12	BOLHF	F HUB BOLTS
3	GARPF12	AGITATOR BELT GUARD	12B	BOLHE	E HUB BOLTS
4	BOL12X112	1/2 X 1 BOLT	13	BOLHSD	SDS HUB BOLTS
5	SH6CE8	6 C8.0 E SHEAVE	14	SH6C18	6 C18.0 F SHEAVE
6	BLTC128	(6) C128 BELT	15	HBSDS1716	SDS 1 7/16
7	BLTBGRP	66 1/2 TWIST LINK BELT	16	N12CT	1/2 CT NUT
8	SH1B124	1B 12.4 SHEAVE	17	KY75X6	3/4 KEYSTOCK
9	GAR12DRL	DRIVE GUARD	19	WL38	3/8 LOCKWASHER
10	SH1B46	1B 4.6 SHEAVE BORED	20	BOL38X1	3/8 X 1 BOLT

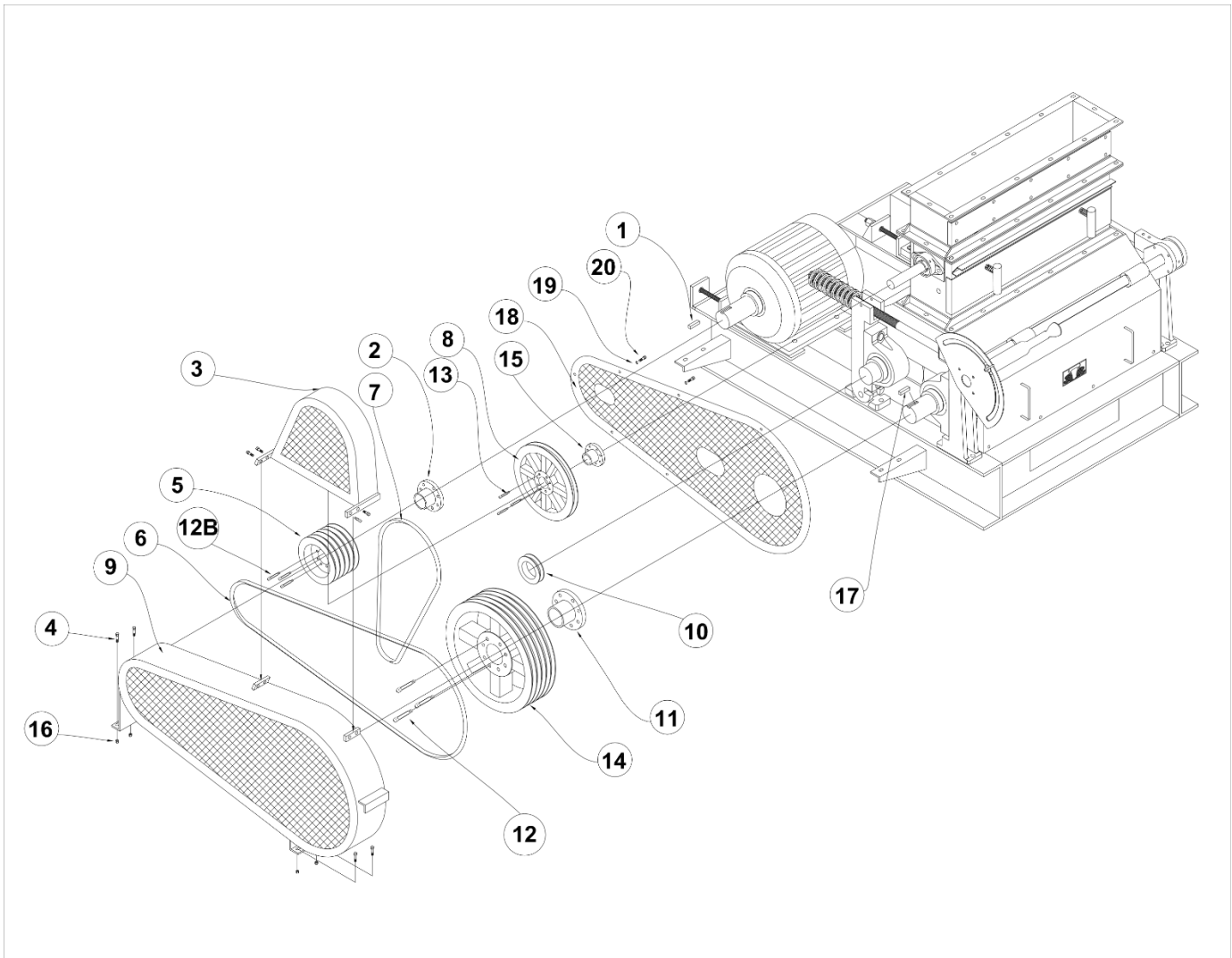

Idler Belt Assembly

Cracker

Crimper

ITEM	ITEM #	PART DESCRIPTION	ITEM	ITEM #	PART DESCRIPTION
1	GAR12	IDLER GUARD	1	GAR12	IDLER GUARD
2	BLTCC105	6 CC105 BELTS	2	BLTCC105	6 CC105 BELTS
3	SH6C18	6 C18.0 F. SHEAVE	3	SH6C18	6 C18.0 F. SHEAVE
4	HBF2716	F 2 7/16 HUB	4	HBF2716	F 2 7/16 HUB
5	N12CT	1/2" NUTS	5	N12CT	1/2" NUTS
6	HBE21516	E 2 15/16 HUB	6	HBE21516	E 2 15/16 HUB
6B	HBF21516	F 2 /15/16 HUB	6B	HBE21516	E 2 /15/16 HUB
8	SH6C11F	6 C 11.0 F. SHEAVE	8	SH6CE8	6 C 8.0 E. SHEAVE
9	SH6CE8	6 C 8.0 E. SHEAVE	9	SH6CE8	6 C 8.0 E. SHEAVE
10	BOLHE	E HUB BOLTS	10	BOLHE	E HUB BOLTS
10B	BOLHF	F HUB BOLTS	10B	BOLHE	E HUB BOLTS
12	BOLHF	F HUB BOLTS	12	BOLHF	F HUB BOLTS
13	BOL12X1	1/2 X 1 BOLTS	13	BOL12X1	1/2 X 1 BOLTS
14	KY75X50	3/4 X 1/2 KEYSTOCK	14	KY75X50	3/4 X 1/2 KEYSTOCK
14B	KY75X6	3/4 KEYSTOCK	14B	KY75X50	3/4 X 1/2 KEYSTOCK
15	BRG2716QM	2 7/16 HD QM BEARING	15	BRG2716QM	2 7/16 HD QM BEARING
16	IDL02C	2 7/16 IDLER SHAFT	16	IDL02C	2 7/16 IDLER SHAFT
17	IDL12M	IDLER MOUNT	17	IDL12M	IDLER MOUNT

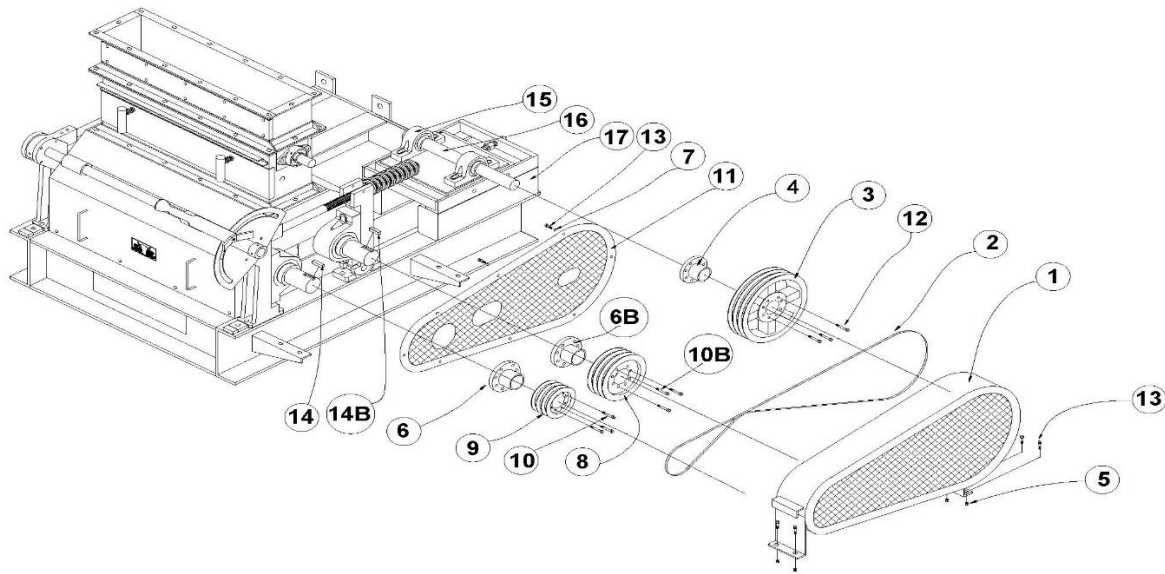

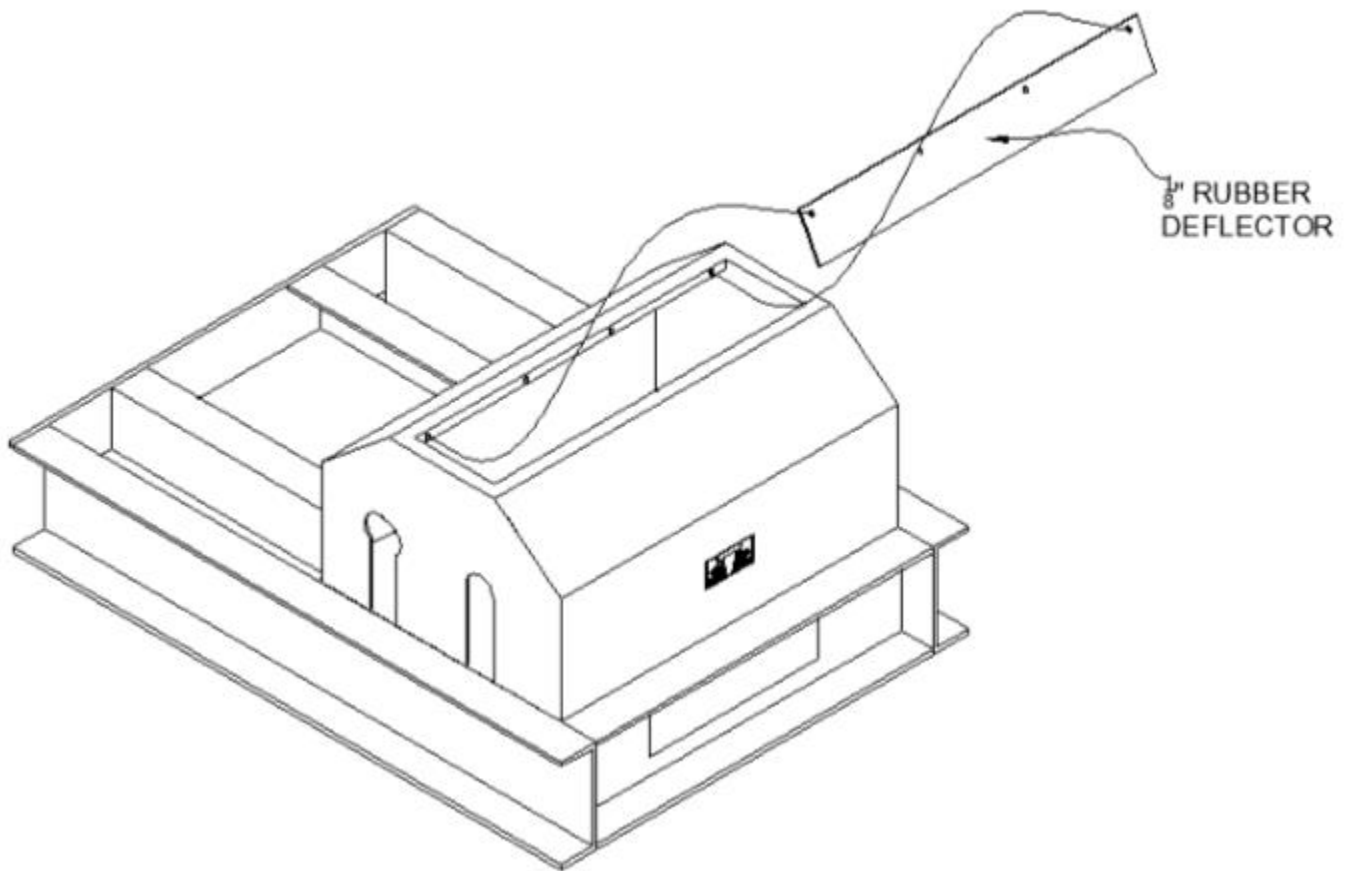

Roll and Cabinet Assembly

ITEM	ITEM #	PART DESCRIPTION
1	IDL12M	IDLER MOUNT
4	FR125	ROLL CABINET
5	SAD12VU	12 SADDLE
6	PFAG125M	MAGNET CABINET
7	PFAG1252	AGITATOR CABINET
8	R1252R	FOLLOW ROLL
9	R1252DR	DRIVE ROLL
11	BOL38X1	3/8 X 1 BOLT
12	BOL38X2	3/8 X 2 BOLT
13	FR12CS	12" CRACKER CENTER SECTION
14	DOR0012	CRACKER INSPECTION DOOR

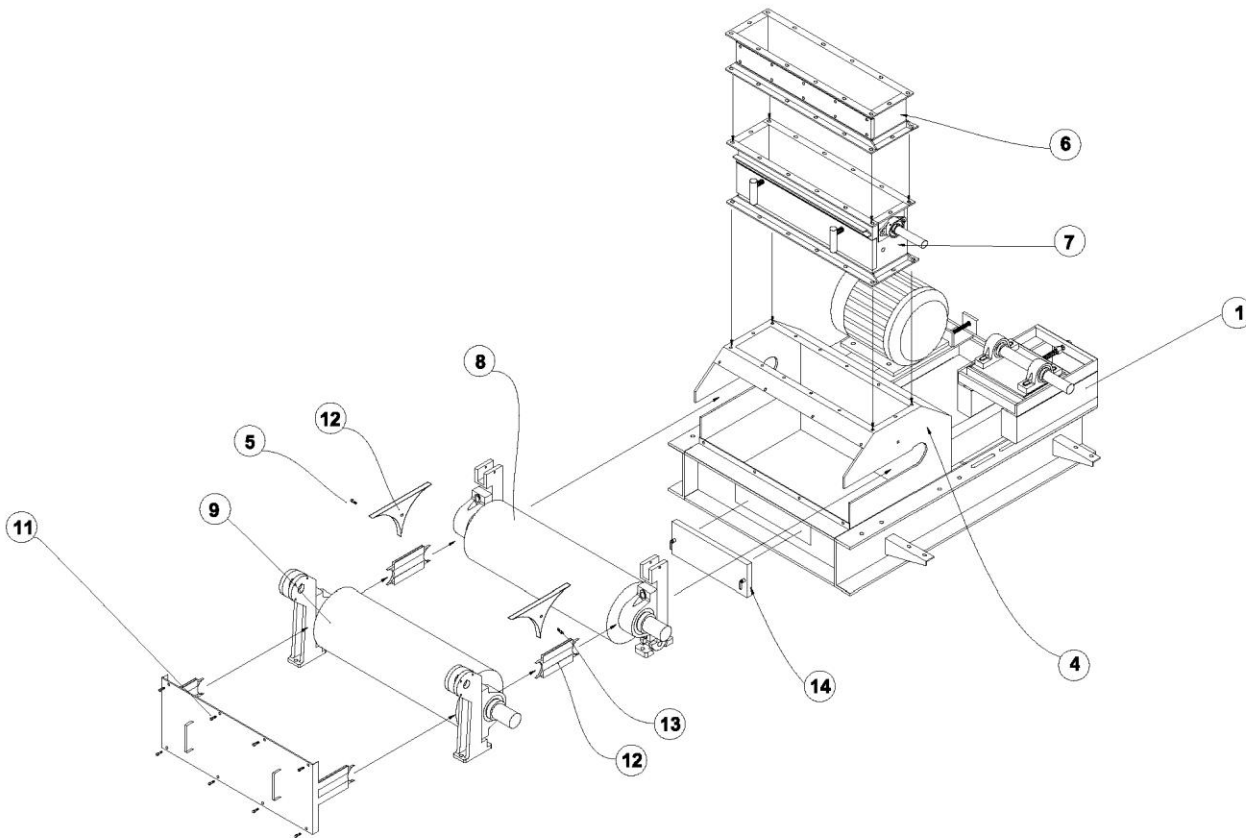

Agitator Feeder Cabinet Assembly

ITEM	ITEM #	PART DESCRIPTION
1	PFAG1252	AGITATOR CABINET
2	PFAGB5	AGITATOR BAR
3	PFAGF	BEARING FLANGE
4	BRG1716FB	1-7/16 FLANGE BEARING
5	PFAG1252S	SHUT OFF GATE ASSY
6	PFCABRK	R8 X 6 FT STEEL RACK
7	MCRR34	3/4 CRR SHAFT
8	PFCABPN	3/4 BAR PINION GEAR
9	DOR0018H	DOOR HANDLE
10	DORMD18	M/S DOOR HINGE
11	N12CT	1/2 NUT
12	PFKNB38	DOG POINT STAR KNOB
13	WL12	1/2 LOCK WASHER
14	BOL12X2	1/2 X 2 BOLT (WELDED ON)

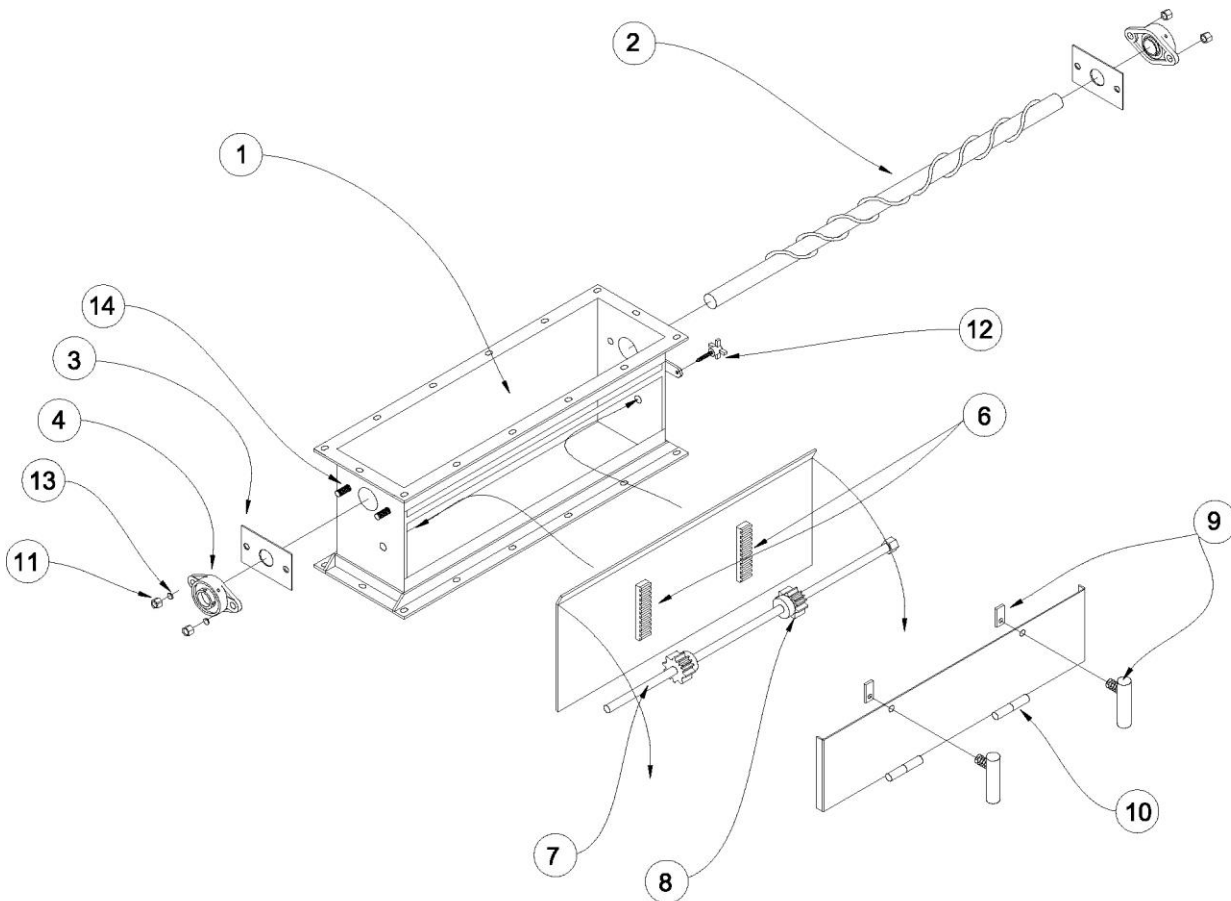

Magnet Cabinet Assembly

ITEM	ITEM #	PART DESCRIPTION
1	PFAG125M	MAGNET CABINET
2	MAG848	MAGNET

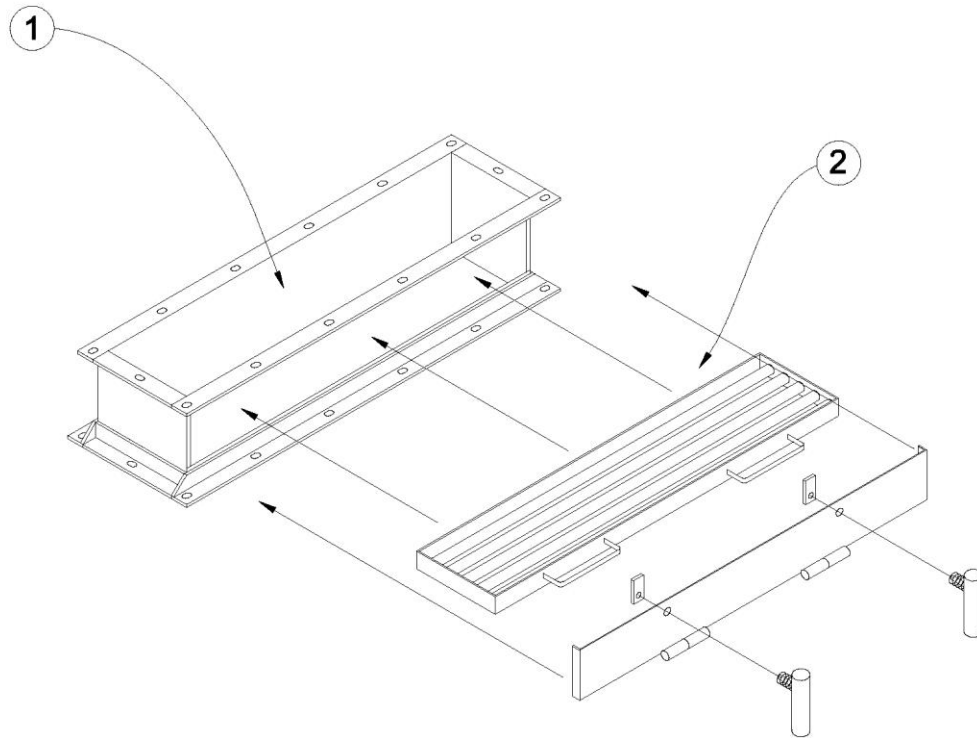

Limited Warranty

The manufacturer warrants this equipment to the original user against material or workmanship for a period of 30 days from the date of purchase on repair parts and labor. The manufacturer's responsibility under this warranty is limited to the repair or replacement of defective part or parts.

The manufacturer reserves the right to determine whether the part or parts failed because of material, workmanship, or other causes. Failure caused by accident, alteration, or misuse is not covered by this warranty.

A DALHART R&R MACHINE WORKS, INC. representative must perform all warranty repairs. Any repair to the equipment other than by this authorized facility voids this warranty. The rights under this warranty are limited to the original user and may not be transferred to subsequent owners.

The warranty is in lieu of all other warranties, expressed or implied, including warranties for a specific purpose.



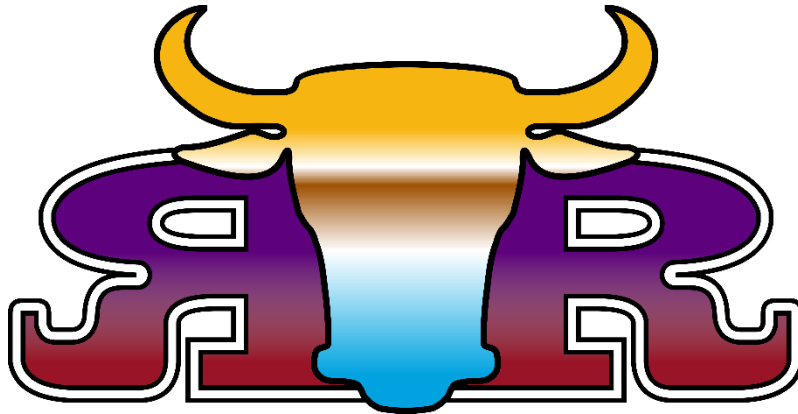

12 X 52 Cracker Mill Operator's Manual and Parts Guide

Corporate Office:
P.O. Box 1330
1006 Liberal Street
Dalhart, TX 79022

Phone: (806) 244-5686
Fax: (806) 244-6096

www.r-rmachine.com
sales@r-rmachine.com