

R & R Machine Works Inc.

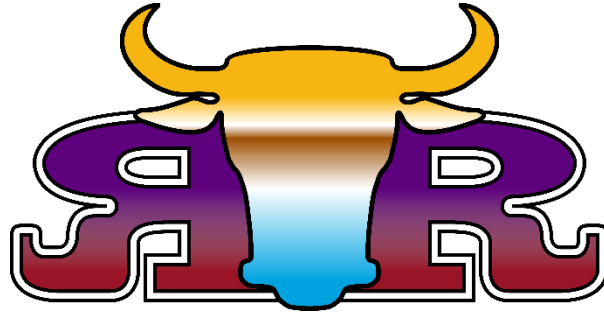

We really appreciate you making this purchase from us and we hope the equipment meets your expectations. We strive to sell equipment that will make your business as well as ours, prosper. When you have future equipment or service needs please think of us first!

If we can be of further services to you or your company,
please call us at (806) 244-5686.

Sincerely,

Owners and Management
Dalhart R&R Machine Works, Inc.

Table of Contents

Introduction	1
Safety	2
Safety	3
Machine Overview	4
Installation	5
Pre-Operation Checklist	5
Grain Cleaner Start Up Procedure	6
Start Up Procedure	6
Operation / Monitoring	7
Shut Down Procedure	7
Shut Down	7
Maintenance	8
Maintenance Schedule	8
Lubrication	8
Belt Tension	8
Grain Cleaner Inspection Door.....	11
Inspection Door Installation/Removal	11
Removal	11
Installation	11
Grain Cleaner Screen Change	12
Removal of grain screen.....	12
Installation of grain screen	12
Grain Cleaner Brush Maintenance	14
Screen Brush Adjustment	14
Parts Lists and Diagrams	15
Enclosure and Hoppers	15
Trommel and Screen	16
Inspection Door and Brush Box.....	17
Guards -Belt and Bearing	18
Power Train	19
Motor Pulleys Belts Gearbox VFD	19
VFD / INVERTOR.....	20
Quick Start Instructions.....	20
Limited Warranty	22

Introduction

Thank you for purchasing a R & R Machine Grain Cleaner. R & R Machine strives to deliver the best grain cleaning technology combined with rugged, durable construction to provide a productive and reliable means of ensuring your product is free from foreign material and debris. To ensure the grain cleaner lives up to all expectations, it is important to read and comply with this manual.

This manual provides personnel with the information needed to safely operate and maintain the R & R Machine Grain Cleaner. It has been designed and written to be used as an instructional tool, as well as a reference tool, for everyday work. It is important that all personnel read and understand the Safety information BEFORE operating the machine. Danger and Caution notices/stickers are positioned in strategic areas on the equipment to point out any potential hazards that may arise from machine setup and/or maintenance procedures.

The parts section includes an ordering guide for assistance when ordering parts. To gain the most from the machine, always use genuine R & R Machine parts. Illustrations may be changed without notice. All dimensions and specifications are approximate, and drawings may not be to scale. Machines may be shown without guards for illustration only. Guards are supplied and must be in place before operation. Specifications are subject to change without notice



Safety

Remember, YOU are the key to safety. Good safety practices not only protect you, but also the people around you. Make these practices a working part of your safety program. Be certain that everyone operating this equipment is familiar with the recommended operating and maintenance procedures and follows all the safety precautions. Most accidents can be prevented. Do not risk injury or death by ignoring good safety practices.

OPERATING SAFETY

1. Read and understand the Operator's Manual and all safety signs before using.
 2. Before servicing, adjusting, repairing, or maintaining unit, ensure that unit power source is completely shut down, and cannot start-up (locked out).
 3. Do not operate when any guards are damaged or removed. Install and secure guards before starting.
 4. Do not operate when any inspection doors are damaged or removed. Install and secure the doors before starting.
 5. Keep hands, feet, clothing, and hair away from all moving and/or rotating parts.
 6. Wear appropriate ear protection when operating for long periods of time.
 7. Review safety items with all personnel routinely.
- **DO NOT** modify the equipment in any way. Unauthorized modification will affect the warranty and may impair the function and / or safety and could affect the life of the equipment.
 - **DO NOT** make any adjustments or repairs on the equipment while the machine is running.
 - **DO NOT** start the system loaded with grain.
 - **DO NOT** shutdown the equipment until all the grain and debris has been emptied from the system.

SIGNAL WORDS:

Note the use of the signal words DANGER, WARNING, and CAUTION with the safety messages. The appropriate signal word for each message has been selected using the following guidelines:

DANGER - Indicates an imminently hazardous situation that, if not avoided, will result in death or serious injury. This signal word is to be limited to the most extreme situations, typically for machine components that, for functional purposes, cannot be guarded.

WARNING - Indicates a potentially hazardous situation that, if not avoided, could result in death or serious injury and includes hazards that are exposed when guards are removed. It may be also used to alert against unsafe practices.

CAUTION - Indicates a potentially hazardous situation that, if not avoided, may result in minor or moderate injury. It may be also used to alert against unsafe practices.



Safety



**KEEP HANDS CLEAR
WHEN
EQUIPMENT
IS RUNNING**



**NO ACERQUE
LAS MANOS
CUANDO EL EQUIPO
ESTE FUNCIONANDO**



CAUTION

**DO NOT OPERATE
THIS MACHINE
WITHOUT GUARDS
IN PLACE**

PRECAUCION

**NO MANEJE
ESTA MÁQUINA
SIN GUARDIAS
EN POSICIÓN**



**LOCK-OUT
BEFORE WORKING
ON EQUIPMENT**



**CERRAR CON LLAVE
ANTES DE TRABAJAR
EN EL EQUIPO**

SAFETY SIGN REPLACEMENT

1. Keep safety signs clean and legible always.
2. Replace safety signs that are missing or have become illegible.
3. Replaced parts that displayed a safety sign should also display the current sign.
4. Safety signs are available from R & R Machine.



Machine Overview

R & R Machine Works grain cleaner moves grain gently through a rotary system of screens to economically remove any foreign material.

As the drum rotates, three processes occur.

1. The grain moves the length of the drum to the discharge end.
2. Then the grain moves laterally across the diameter of the drum.
3. The grain is constantly stirred to pass the grain over the screen repeatedly while it is moving directionally.

Debris and fines are thoroughly removed from the grain with the fines being separated from larger screenings and scalped grain. All of these, fines, scalped grain, and debris, are deposited in separate output chutes.

The key to effective grain cleaning is to obtain the correct correlation of the rate of inflow of grain with the speed of the rotary screens. This will ensure that the maximum amount of clean grain is produced with the minimum of foreign materials. To accomplish this, R & R Machine incorporates a VFD (variable frequency drive) to allow the fine tuning of the screen rotation speed. This is a unique feature of the R & R Machine Grain Cleaner.

Screen Size

The configuration is (1) sifting screen for fines removal and (2) scalping screens for scalping. R & R Machine provides several additional grain screen sizes to address specific types of product to be cleaned. Please contact R & R Machine at (806) 244-5686 to discuss your requirements.



Installation

The installation of your grain cleaner should be carefully planned and well-engineered.

The following points should be followed to get the most out of your grain cleaner, both in capacity and quality:

1. Sufficient space must be available around the grain cleaner for adjustments, repairs and removal and installation of roll screens.
 - i. This space should be maintained for future maintenance.
2. The grain cleaner should be installed on a level surface capable of withstanding the weight of the cleaner. Micro/Level Isolators are ideal to place between the cleaner frame and the floor that the cleaner is to be mounted on.
 - i. If the surface is not level, shims or grout should be used to avoid warping or binding the frame.
3. Provision should be made for the following:
 - a. Adequate electrical voltage and amperage to operate the cleaner
 - b. Adequate grain is available to the cleaner for processing
 - c. Removal of the processed grain equivalent to the rate of processing
 - i. This may be done in any of several methods

Pre-Operation Checklist

Efficient and safe operation of the R & R Machine grain cleaner requires that each operator reads and understands the operating procedures and all related safety precautions outlined in this section. A pre-operation checklist is provided for the operator. It is important for both personal safety and protection of the grain cleaner that this checklist is followed.

Before operating the grain cleaner and each time thereafter, the following areas should be checked off:

1. Lubricate the equipment per the schedule outlined on the Maintenance Schedule.
2. Check the equipment for damaged, worn, loose, or missing parts.
 - a. Repair as needed before operation.
3. Check the screens/drums.
 - a. Remove any twine, wire or other foreign material that has become entangled.
4. Check belt tension.
 - a. Belt tension must be maintained to assure maximum belt life.
 - b. Remove any trash, which might accumulate in the pulley grooves.
5. Check that all bearings turn freely. Replace any that need replacing.
6. Make sure that all guards and shields are in place, secured and functioning as designed.



Grain Cleaner Start Up Procedure

The key to effective grain cleaning is to obtain the correct correlation of the rate of inflow of grain with the speed of the rotary screens. This will ensure that the maximum amount of clean grain is produced with the minimum of foreign materials.

This can be accomplished by the observation of the number of fines in the scalped grain and the amount of grain in the overage/debris. This will vary depending on the ability to easily observe the fines and overage/debris outputs.

Start Up Procedure

The R & R Machine Grain Cleaner is equipped with an industry leading VFD (variable frequency drive) or also referred to as an inverter. The operation of the drive motor for the grain cleaner is controlled by this device.

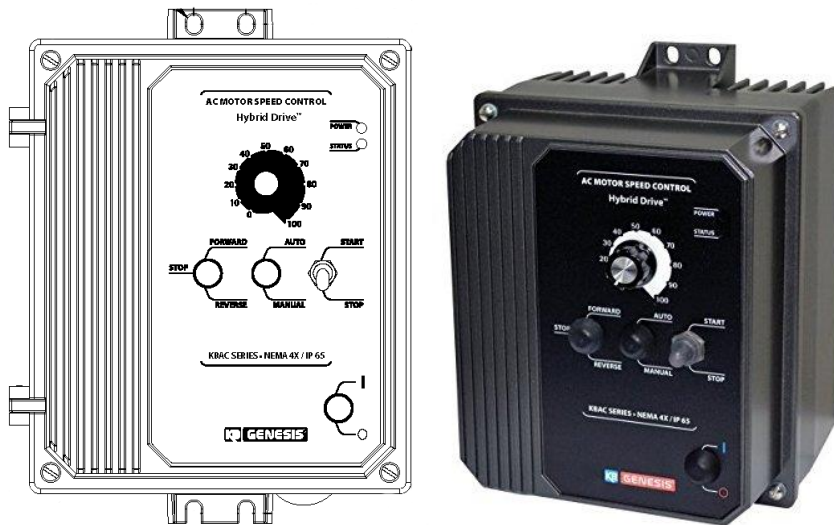

To start the drive, momentarily set the Start/Stop Switch to the “START” position. The motor will begin to accelerate to the set speed.

Initial Setup

The initial setup of the amount of inflow vs the speed must be observed and modified accordingly. Once you have established this setting, this will be your starting point for successive operations of the grain cleaner.

1. Ensure the grain cleaner pre-operation checklist has been completed.
2. Start the grain cleaner
 - a. Ensure that the drum rotation is CCW from inlet
3. Start the grain input flow
4. Input flow / rotation speed setting
 - a. Incrementally increase the rotation speed of the drum until you observe grain in the scalping discharge
 - b. Secondary check
 - i. If you observe excessive fines, in the scalped grain
 1. If excessive speed – reduce speed
 2. If minimal speed- increase speed
 3. Adjust brushes



Operation / Monitoring

Grain flow into the cleaner can be controlled with the jump auger flow gate to ensure that the flow is matching the output of the grain cleaner.

1. After the initial setup is complete
2. Periodically review the outputs – if adjustments are required perform the following
 - a. Fines in the scalped grain is excessive
 - i. Reduce the speed of rotation for the screens
 - b. Grain in the overage/debris is excessive
 - i. Reduce the speed of rotation for the screens

Shut Down Procedure

Shut Down

1. Shut down the grain inflow
2. Continue to operate the grain cleaner until all the residual grain has been processed through all the screens
3. Stop VFD



Maintenance

Maintenance Schedule

	Description	Service Item				
		Check	Clean	Lube	Adjust	
Daily Maintenance						
	Screens/Drums	✓	✓			
	Pulleys and Belt Tension	✓				
	Guards and Shields	✓				
Weekly Maintenance						
	Pillow Block Bearings	✓		✓		
	Brush Clearance	✓			✓	
	Gearbox Oil Level	✓		✓		
Monthly Maintenance						
	Screen Brushes	✓	✓		✓	
Annual Maintenance						
	Entire Machine	✓	✓			

Maintenance work must be done at regular intervals. Failure to do so will result in excessive wear and early failures. The service schedule is only a guide for correct maintenance of the equipment.

Lubrication

1. Grease pillow block bearings once a week per the maintenance schedule.
 - a. Use an SAE multi-purpose high temperature grease with extreme pressure (EP) characteristics. Also acceptable is an SAE multi-purpose lithium-based grease.
2. Clean fitting before greasing, to avoid injecting dirt and grit.
3. Replace and repair broken fittings immediately.
 - a. If fittings will not take grease, remove and clean thoroughly. Replace fitting if necessary.
4. Always use a hand-held grease gun.
5. Apply two to three pumps of grease to the pillow bearings.

Belt Tension

Rotational power from the power source is transmitted to the auger and brush shaft through the belt drive. To obtain efficient transmission of power and good belt life, the belts must be properly tensioned, and the pulleys aligned. Belts that are too tight will stretch and wear quickly or overload the bearings. Belts that are too loose will not transmit the required power and will slip, overheat, and wear quickly. Pulleys that are not aligned will result in rapid belt wear.

The R & R grain cleaner is equipped with (3) B-Series belts. These belts are designed to work in tandem for optimal efficiency. If one belt becomes worn or stretched, all three belts are to be replaced. Replacing only individual belts and not all three will result in reduced belt life and potential failure of the belts.

New or replaced belts



Belt tension should be rechecked after two days of operation and adjusted, if required.

Follow this procedure when checking and adjusting belt tension and pulley alignment.

1. Shut down the cleaner and wait for all moving parts to stop before attempting any adjustment.
2. Ensure that the unit power source is completely shut down and locked out.
3. Unbolt the latch bolt of the belt guard and swing the belt guard cover away from the motor/pulleys
 - a. If necessary, secure the belt guard door in the open position.

Check Tension

1. Determine the belt deflection in a static condition on the machine.
 - a. At the midpoint, between both pulleys, depress the belt (push toward the opposite side) and estimate the amount of deflection
 - b. There should be approximately 7/16 of an inch of deflection

Adjusting Tension

The grain cleaner motor is attached to a mounting plate. The mounting plate has four adjustment bolts/nuts for tension adjustment. Adjust the belt to the appropriate tension.

1. Loosen the jam nuts (nuts on the top of the mounting plate) on the adjusting bolts to allow for belt adjustment.
2. To tighten the belt adjustment, turn the adjusting nuts (nuts on the bottom of the mounting plate) CCW to set the tension.
 - a. Nuts must be adjusted in sequence and with equal adjustments.
 - i. If one adjustment nut is adjusted a quarter of a turn CCW – ALL must be adjusted the same amount
3. To loosen the belt adjustment, turn the adjusting nuts (nuts on the bottom of the mounting plate) CW to set the tension.
 - a. Nuts must be adjusted in sequence and with equal adjustments.
 - i. If one adjustment nut is adjusted a quarter of a turn CW – ALL must be adjusted the same amount
4. Check the tension again. (Over-tightening will cause belt stretching and overload the motor/gearbox. Belts that are too loose will slip, tear, and wear rapidly.
5. Once appropriate tension is gained, tighten all jam nuts (nuts on the top of the mounting plate).
6. Swing the belt cover back into the closed position and bolt in place.



Pulley Alignment

The alignment of the pulleys/sheaves between the motor and the gearbox shaft is key to belt life and safety. Should the pulleys/sheaves become out of alignment, premature belt wear and potential belt breakage or being “rolled” off of the pulleys/sheaves may occur.

1. Unbolt the latch bolt of the belt guard and swing the belt guard cover away from the motor/pulleys.
 - a. If necessary, secure the belt guard door in the open position.
2. Lay a straight edge across the faces of the two pulleys.
3. If the gap between the pulley and the straight edge exceeds 1/16 inch (1.5mm), the pulleys must be realigned.
4. Measure the distance the pulley needs to move.
5. Loosen belts.
6. Lift off the belts
7. Loosen and remove bolts from the pulley which is to be moved.
8. Install bolts into pulley’s threaded holes and progressively tighten each one until pulley is loose on bushing
9. Move bushing as per measurement required.
10. Remove bolts from pulley’s threaded holes and return to the bushing.
11. Re-install sheave onto bushing
12. Tighten bolts
13. Re-install belts
14. Adjust belt tension.



Grain Cleaner Inspection Door

Inspection Door Installation/Removal

The removal of the inspection door is to facilitate various maintenance and inspection procedures for the grain cleaner.

Removal

1. Ensure that the equipment is completely shut down and appropriate “lock out” is performed prior to engaging in this procedure.
2. Release cam latches on the inspection door
3. Utilizing both oval grip handles, lift the door upward and toward you
4. Set the door aside in a safe area

Installation

1. Utilizing both oval grip handles and keeping the door parallel to the machine, lift and place the bottom of the inspection door along the frame with the top of the door at a slight outward angle (toward you)
2. Once the door is resting on the frame, gently maneuver the door into position
3. Close all cam latches to secure the door



Grain Cleaner Screen Change

Removal of grain screen

The removal of the grain screen is best accomplished with two individuals to assist with the rotation of the trommel during the removal process.

1. Ensure that the equipment is completely shut down and appropriate “lock out” is performed prior to engaging in this procedure.
2. Remove inspection door
 - a. Release the cam latches
 - b. Utilizing both oval grips, lift upward and towards you.
 - c. Set aside
3. Raise brushes to provide adequate clearance.
4. Remove the inspection door frame
 - a. Remove the two attaching bolts at the top and bottom of the frame.
 - b. Set the frame and bolts aside for re-installation.
5. Rotate trommel until the screen attachment bars are in position for bolt removal.
6. Loosen the three tensioning bolts on the screen.
 - a. Loosen and remove the two outside bolts leaving the center bolt.
 - b. Loosen the center bolt gradually until the screen tension is released.
 - c. Once the tension is released, remove the bolts and nuts and keep for installation of new screen.
7. Loosen the two attachment bolts from the screen.
 - a. Take care when loosening the bolts as the screen will be released from the frame as they are removed.
 - b. Remove the bolts and keep for installation of the new screen.
 - c. Take hold of the screen and pull towards you and rotate the screen down and under the frame of the cleaner until the screen is removed.
 - d. Discard the old screen.

Installation of grain screen

The installation of the grain screen is best accomplished with two individuals to assist with the rotation of the trommel during the installation process.

1. Remove inspection door of the screen to be installed.
2. Rotate trommel until the screen attachment bars are in position for bolt installation.
 - a. This should be close to the mid-point of the inspection door opening.
3. Place the screen perpendicular to the machine and gently spread the screen opening until the screen can be placed around the trommel.
 - a. Both edges of the screen should be in view, one above the attachment bar and one below.
4. Once the screen is around the trommel, align the screen attachment bolt holes with the threaded holes in the attachment bar. You may have to pick up the screen end from inside the hopper
 - a. Place an attachment bolt in the first attachment hole and hand tighten.
 - b. Align the second attachment hole and place an attachment bolt in the second hole and hand tighten.
 - i. Ensure that the screen is centered.
 - c. Tighten the two attachment bolts.
5. Bring the loose edge of the screen toward the attachment bar until the tension bolts can be installed.
 - a. Install the center tension bolt first and hand tighten



- b. Install the remaining two tension bolts and hand tighten
 - c. Tighten the center tension bolt and then the two outside tension bolts gradually, in sequence, until the screen has adequate tension.
6. Rotate the trommel, manually, to ensure that the screen rotates freely.
 - a. If it does not rotate freely, perform an inspection to determine the cause and remove.
7. Lower brushes and readjust to appropriate clearance.
8. Replace the inspection door frame
 - a. Align the upper frame attachment holes, install bolts and hand tighten
 - b. Align the lower frame attachment holes, install bolts and hand tighten.
 - c. Tighten all bolts
9. Replace inspection door
 - a. Place inspection door in frame
 - b. Close all cam latches
 - c. Ensure door is secured



Grain Cleaner Brush Maintenance

Screen Brush Adjustment

The screen brush adjustment is performed to ensure that the brush has the proper contact with the screen to remove loose debris.

1. Ensure that the equipment is completely shut down and appropriate “lock out” is performed prior to engaging in this procedure.
2. Remove inspection door
3. Inspect the screen
 - a. If debris is on the outside of the screen and can be easily wiped away, then the brush needs adjustment
4. Adjustment of the brush
 - a. The brush is raised and lowered by the brush adjustment nuts on the top of the brush box. The brush is under spring tension.
 - i. To raise the brush, tighten the nut (CW)
 - ii. To lower the brush, loosen the nut (CCW)
 - b. The brush should only make light contact with the screen.
 - i. Too much contact will result in premature wear of the brush
 - ii. Too little contact will result in the screens becoming clogged.
 - c. Lower the brush until there is even contact across the screen.
 - d. Lower the brush an additional 1/4 turn on each adjustment nut.



Parts Lists and Diagrams

Enclosure and Hoppers

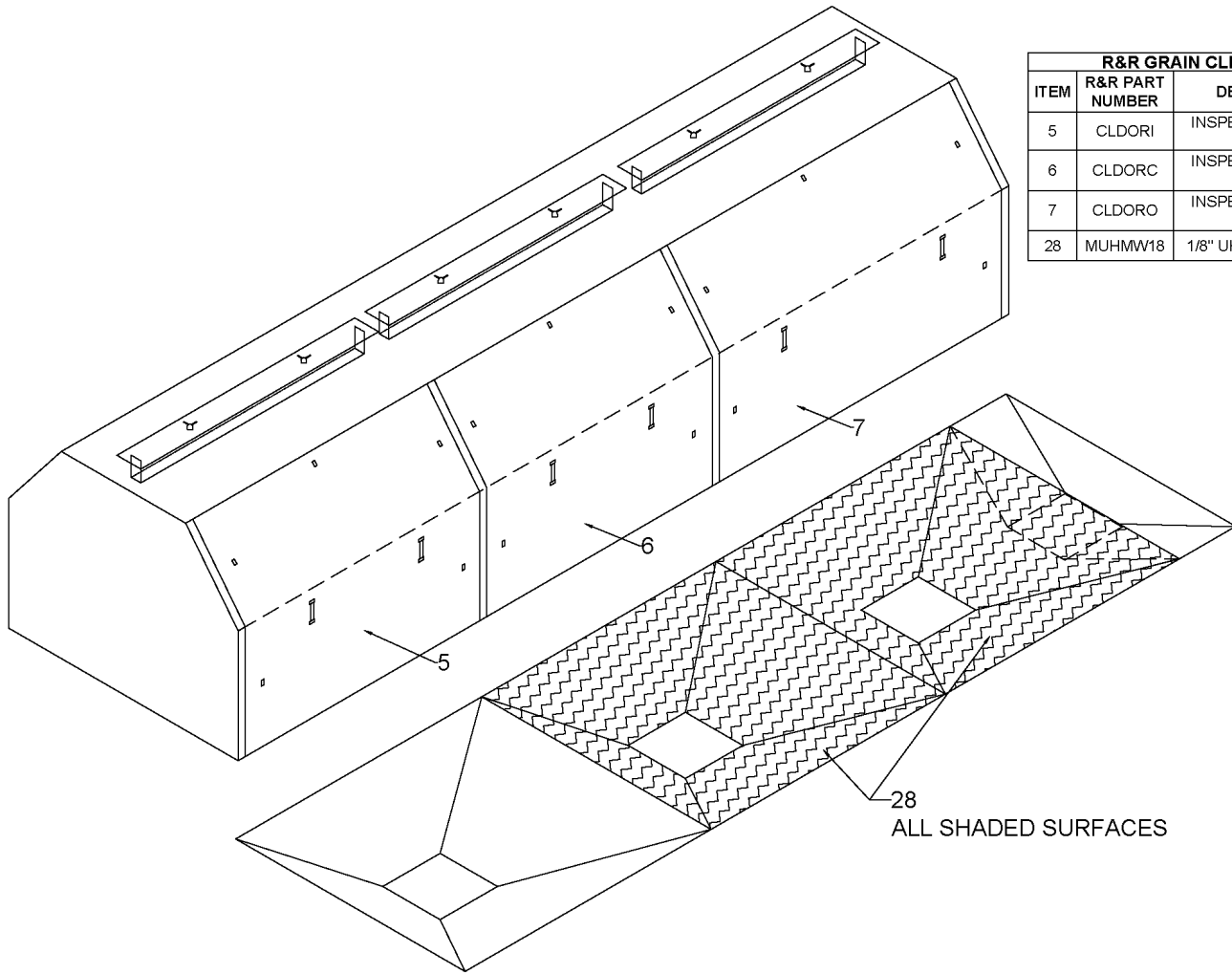

R&R GRAIN CLEANER		
ITEM	R&R PART NUMBER	DESCRIPTION
5	CLDORI	INSPECTION DOOR - INLET
6	CLDORC	INSPECTION DOOR - CENTER
7	CLDORO	INSPECTION DOOR - OUTLET
28	MUHMW18	1/8" UHMW SHEETING

Trommel and Screen

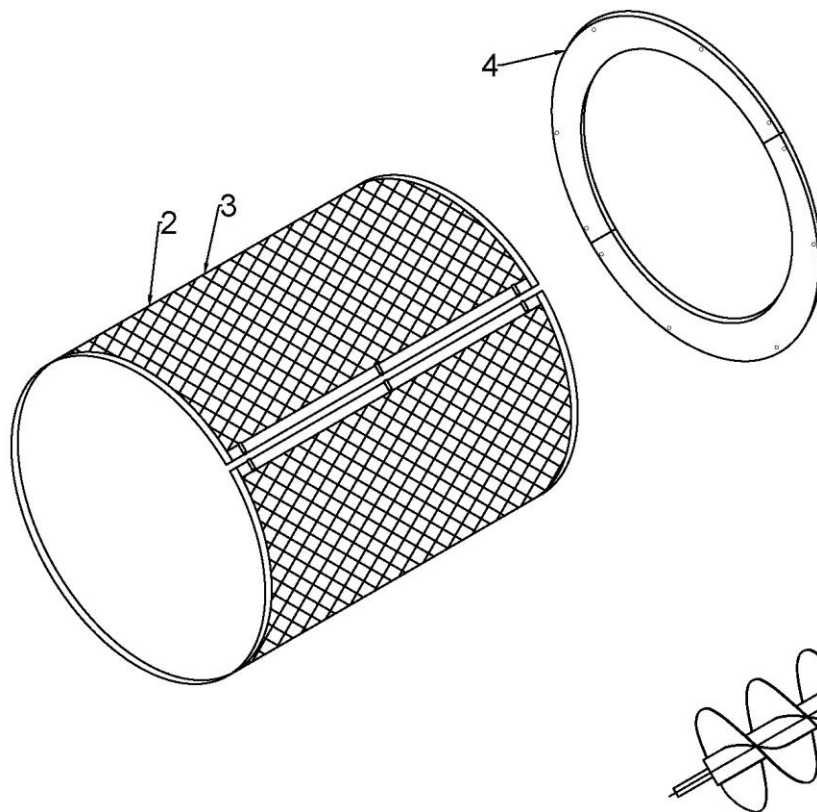

R&R GRAIN CLEANER		
ITEM	R&R PART NUMBER	DESCRIPTION
1	CLTR36X3	36" 3-SCREEN TROMMEL
2	CLS12	36" X SCALPING SCREEN
3	CLS316	36" X SIFTING SCREEN
4	CLTG	TROMMEL GASKET

Inspection Door and Brush Box

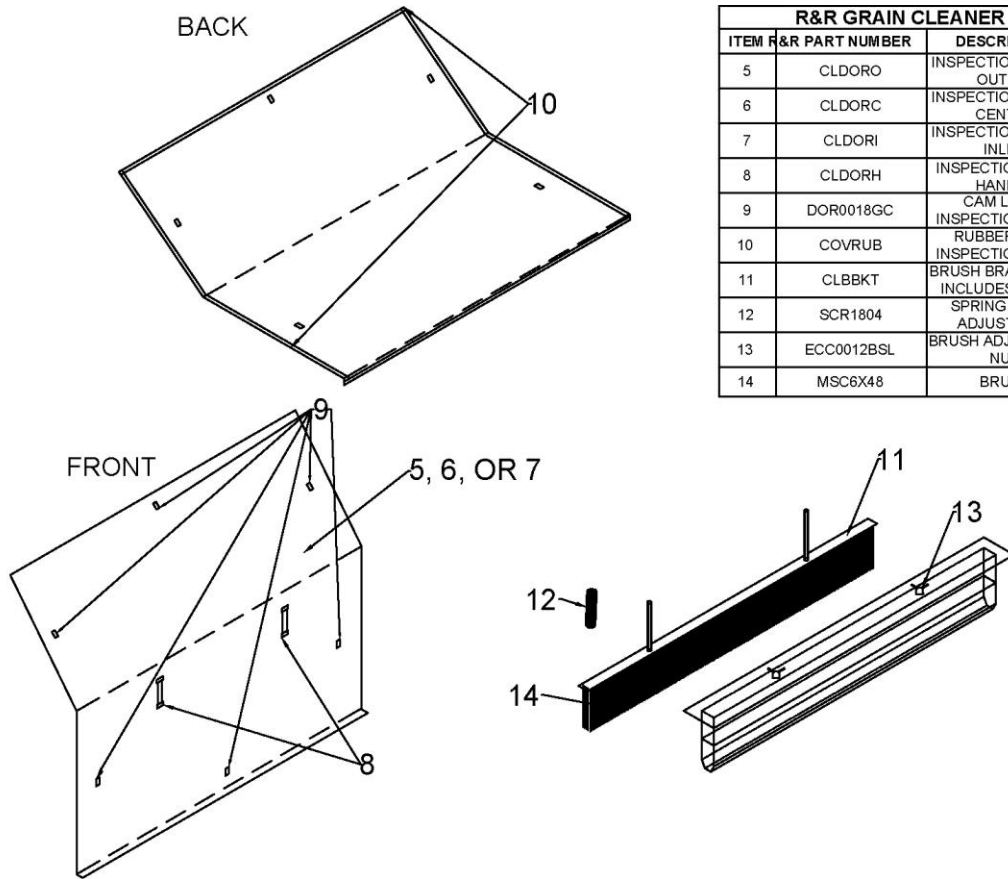

R&R GRAIN CLEANER		
ITEM #	R&R PART NUMBER	DESCRIPTION
5	CLDORO	INSPECTION DOOR - OUTLET
6	CLDORC	INSPECTION DOOR - CENTER
7	CLDORI	INSPECTION DOOR - INLET
8	CLDORH	INSPECTION DOOR HANDLE
9	DOR0018GC	CAM LATCH INSPECTION DOOR
10	COVRUB	RUBBER SEAL INSPECTION DOOR
11	CLBBKT	BRUSH BRACKET KIT INCLUDES 12 & 13
12	SCR1804	SPRING BRUSH ADJUSTMENT
13	ECC0012BSL	BRUSH ADJUSTMENT NUT
14	MSC6X48	BRUSH

Guards -Belt and Bearing

R&R GRAIN CLEANER		
ITEM	R&R PART NUMBER	DESCRIPTION
15	CLGAR	BELT GUARD
16	CLGARS	SHAFT BEARING GUARD
17	CLGARB	STUB BEARING GUARD

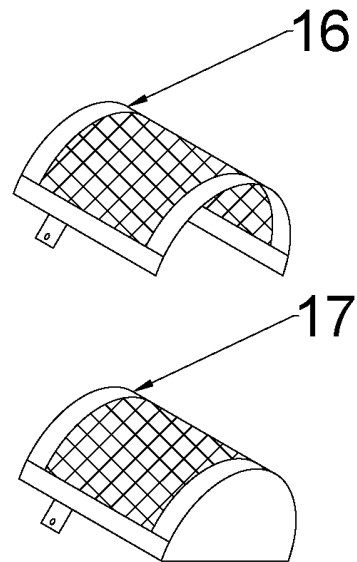
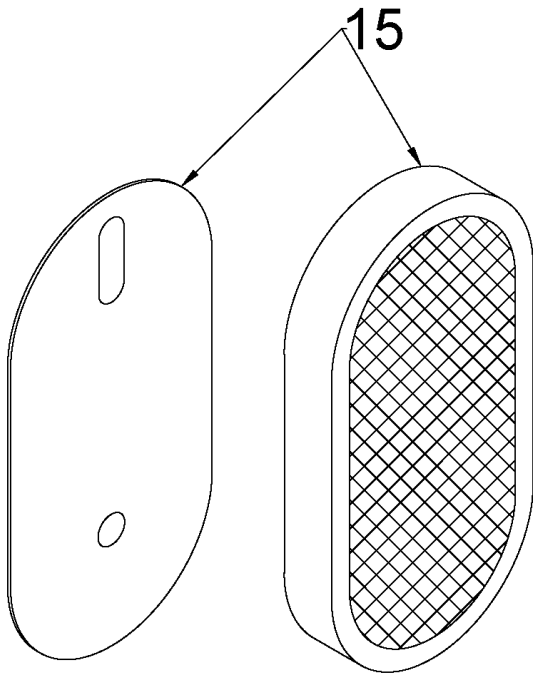

Power Train
Motor Pulleys Belts Gearbox VFD

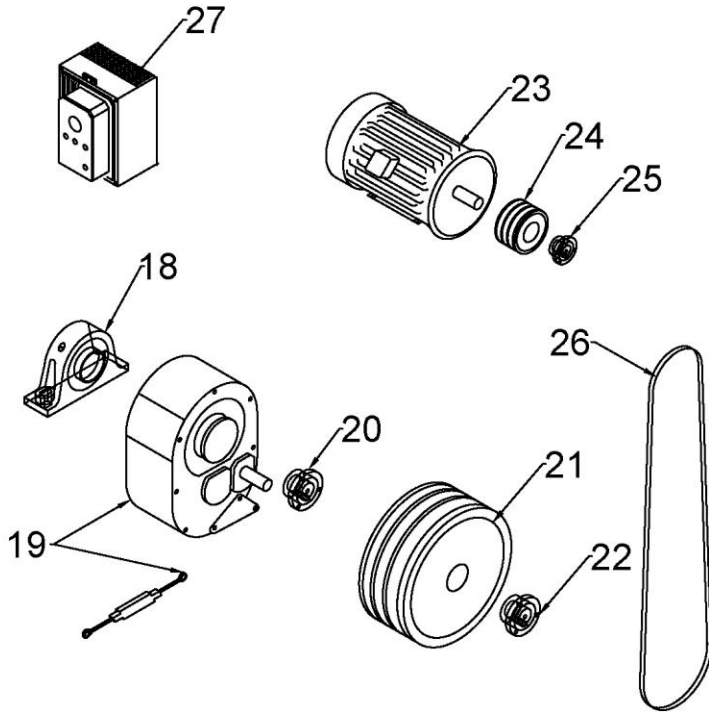

R&R GRAIN CLEANER		
ITEM	R&R PART NUMBER	DESCRIPTION
18	BRG21516QME	PILLOW BLOCK BEARING - TRUMMEL
19	GBD4	GEARBOX
20	HBTDT4	GEARBOX HUB KIT
21	SH3B11	GEARBOX PULLEY
22	HBSK1716	GEARBOX PULLEY HUB
23	MTR5HP1800	5HP MOTOR-3PH 1800
24	SH3B54	MOTOR PULLEY
25	HBSD118	MOTOR PULLEY HUB
26	BLTB68	B68 BELT (3 REQUIRED)
27	CLECBP	VARIABLE FREQUENCY DRIVE

VFD / INVERTOR

Quick Start Instructions

KBAC SERIES QUICK-START INSTRUCTIONS

FOR TECHNICAL ASSISTANCE
CONTACT OUR SALES DEPARTMENT AT 954-346-4900
CALL TOLL FREE 800-221-6570

For Complete Details and Instructions, See the
KBAC Installation and Operation Manual Online



Scan this QR Code

1 - INITIAL SETUP AND CONNECTIONS

Wire the drive in accordance with National Electrical Code requirements and other local codes that may apply to the application. [Factory jumper settings shown in bold.]

1. Set Jumper J1 (Models KBAC-24D, 27D only) to the corresponding AC Line Input voltage (230V, 115V).
2. Set Jumper J2 to the corresponding position for the motor being used.
3. Set Jumper J3 for Automatic Ride-Through or Manual Start Mode (A, M).
4. Set Jumper J4 to the motor frequency multiplier (1X, 2X).
5. Set Jumper J5 to the rated motor frequency (60 Hz, 50 Hz).
6. Set Jumper J6 to the desired Boost Mode (FIX, ADJ).
7. Set Jumper J8 to the desired Run/Fault Output Relay Operation (R, F).
8. Set Jumper J9 for the Stop Contact type being used (NO, NC).
9. Set Jumper J10 to the desired Torque Mode (CT, VT).
10. Jumper J11 is for factory use only.
11. Set Jumper J12 (Third Generation (3G) models only) to the desired Switching Frequency or GFCI selection (8K, 12K, G1, G2).
12. Connect the AC Line input to Terminals L1, L2 (1-phase) or L1, L2, L3 (3-phase).
13. Connect the motor to Terminals U, V, W.
14. Connect the ground(s) (earth) to the green ground screw(s) (chassis).

DRIVE LAYOUT AND GENERAL CONNECTION DIAGRAM (See Legend, Below Diagram, for Description of Numbered Items)

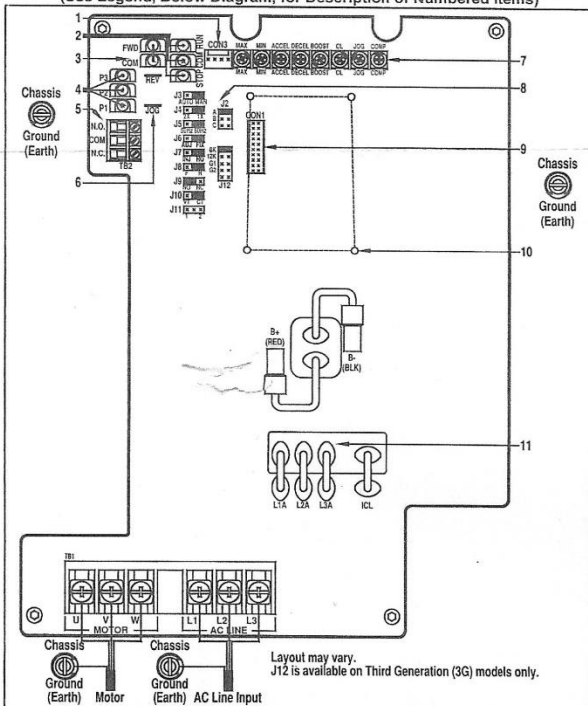

LEGEND: 1. Connector for diagnostic LED board. 2. Terminals for factory installed Start/Stop Switch. 3. Terminals for optional Forward-Stop-Reverse Switch. 4. Terminals for factory installed Main Speed Potentiometer. 5. Terminal block for Run/Fault Relay Output Contacts. 6. Terminal for optional Run-Stop-Jog Switch. 7. Adjustable trim pots. 8. Selectable jumpers. 9. Interface connector for accessories. 10. Four mounting holes for accessories. 11. Terminals for factory installed On/Off AC Line Switch and RFI Filter.

2 - AC LINE FUSING

All fuses should be Littelfuse 312/314, Bussmann ABC, or equivalent.

CAUTION! Do not fuse motor leads.

The drive does not contain AC Line fuses. Most electrical codes require that each ungrounded conductor contain circuit protection. Do not fuse neutral or ground connections. It is recommended to install a fuse or a circuit breaker (Square D QOU or equivalent) in series with each ungrounded conductor.

3 - AC LINE, MOTOR, AND GROUND CONNECTIONS

See the Drive Layout and General Connection Diagram. Download the Installation and Operation Manual by scanning the QR Code at the top left column of this page.

WARNING! High Voltage! Read Safety Warning before using the drive. Disconnect the main power before making connections to the drive. To avoid electric shock, be sure to properly ground the drive.

CAUTION! The rated AC Line voltage of the drive must match the actual AC Line input voltage. On Models KBAC-24D, 27D the setting of Jumper J1 must match the AC Line input voltage.

AC LINE INPUT: Wire the AC Line input to Terminals L1, L2 (1-phase) or L1, L2, L3 (3-phase).

MOTOR: Wire the motor to TB1 Terminals U, V, W.

GROUND: Connect the ground(s) (earth) to the green ground screw(s) (chassis).

4 - ADJUSTABLE TRIMPOTS

The drive contains trim pots which have been factory set for most applications. Some applications may require readjustment of the trim pots in order to tailor the drive for a specific requirement.

Read Safety Warning.

MAXIMUM SPEED (MAX): Sets the maximum speed of the motor when the Main Speed Potentiometer is set fully clockwise. **Units:** % Frequency Setting

MINIMUM SPEED (MIN): Sets the minimum speed of the motor when the Main Speed Potentiometer is set fully counterclockwise. **Units:** % Frequency Setting

ACCELERATION (ACCEL): Sets the time for the motor to accelerate from zero speed to full speed. **Units:** Seconds

DECELERATION (DECEL): Sets the time for the motor to decelerate from full speed to zero speed. **Units:** Seconds

DC INJECTION BRAKE (DECEL): When the drive is set for DC Injection Brake (J7 set to the "INJ" position), the DECEL Trim pot is used to set the amount of time the DC current is applied to the motor. **Units:** Seconds

BOOST (BOOST): When the drive is set for Adjustable Boost (J6 set to the "ADJ" position), the BOOST Trim pot can be used to adjust the amount of boost voltage to the motor. **Units:** Volts

MOTOR OVERLOAD (I²t) WITH RMS CURRENT LIMIT (CL): Sets the current limit (overload), which limits the maximum current to the motor, which prevents motor burnout and eliminates nuisance trips. **Units:** % Full Load

JOG (JOG): Provides a jog speed, which can be used to index a machine into position. It can also be used as a secondary speed setting. Must be used with the optional Run-Stop-Jog Switch (Part No. 9340 or 8889). **Units:** % Frequency Setting

SLIP COMPENSATION (COMP): Sets the amount of Volts/Hz to maintain set motor speed under varying loads. **Units:** Volts/Hz

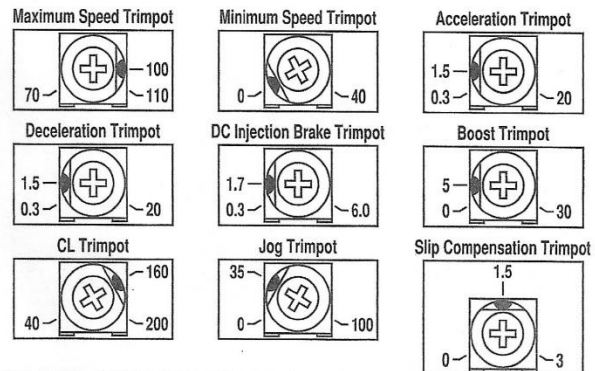

THESE QUICK-START INSTRUCTIONS COVER MODELS

KBAC-24D 2G and 3G⁴ (Part Nos. 9987¹ / 9988²), KBAC-27D 2G and 3G⁴ (Part Nos. 9520¹ / 9667^{1,2} / 9521² / 9669^{2,3}), KBAC-29 (Part Nos. 9528¹ / 9529²), KBAC-29 (1P) (Part Nos. 10001¹ / 10011^{1,2} / 10002²), KBAC-45 (Part Nos. 9530¹ / 9531²), KBAC-48 (Part Nos. 9540¹ / 9541²), KBAC-217 (Part Nos. 8868^{1,4} / 8879^{2,4}), KBAC-217S (Part Nos. 8863^{1,4} / 8855^{2,4}), KBAC-217F (Part Nos. 8861^{1,4} / 8853^{2,4}), KBAC-217SF (Part Nos. 8869^{1,4} / 8880^{2,4}), KBAC-416 (Part Nos. 8870^{1,4} / 8881^{2,4}), KBAC-416S (Part Nos. 8864^{1,4} / 8856^{2,4}), KBAC-416F (Part Nos. 8874^{1,4} / 8883^{2,4}), KBAC-416SF (Part Nos. 8871^{1,4} / 8882^{2,4})

Notes: 1. Gray case. 2. White case (FDA approved finish). 3. Factory programmed for GFCI operation. 4. Third Generation (3G) models have selectable Jumper (J12) for frequency and GFCI selection.



5 - JUMPER SETTINGS

The drive has selectable jumpers which must be set before it can be used.

WARNING! HIGH VOLTAGE! Disconnect the AC Line before changing position of jumpers.

J1 (KBAC-24D, 27D ONLY) (AC LINE INPUT VOLTAGE): J1 is factory installed on Terminal 230V for 208/230 Volt AC Line input. For 115 Volt AC Line input, the jumper must be removed and installed on Terminal 115V.

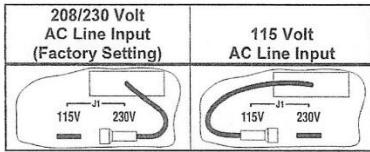

J2 (MOTOR HORSEPOWER): Set J2 to the corresponding position for the motor being used.

KBAC-	24D	27D	29*	29 (1P)*	45*	48*	217 Series*	416 Series*
<input type="checkbox"/>	1	2**	A	3***	3	3	5	10
<input type="checkbox"/>	3/4	1 1/2**	B	2***	2	2	3	7.5
<input type="checkbox"/>	1/2	1	C	1 1/2	1 1/2	1 1/2	2	5
<input type="checkbox"/>	1/4	3/4	D	1	1	1	1 1/2	—
<input type="checkbox"/>	1/8	1/2	E	3/4	3/4	3/4	1	—

The factory setting is shown in bold.

*J2 on KBAC-29, 29 (1P), 45, 48 is labeled "A, B, C, D, E" and on KBAC-217, 416 Series is labeled "A, B, C". ** KBAC-27D is rated 1 1/2 HP maximum with 115 Volt AC Line input and 2 HP maximum with 208/230 Volt AC Line input. *** KBAC-29 is rated 2 HP maximum with 1-phase AC Line input and 3 HP maximum with 3-phase AC Line input.

J3 (AUTOMATIC RIDE-THROUGH OR MANUAL START): J3 is factory set to the "A" position for Automatic Ride-Through. If the power is interrupted for up to 2 seconds, the drive will shut down and then "ride-through" and automatically return to the set frequency. If J3 is set to the "M" position, the drive will have to be manually restarted for a momentary power loss using the Start/Stop Switch.

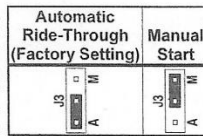

*On KBAC-217, 416 Series and Model KBAC-24D J3 is labeled "AUTO" and "MAN".

J4 AND J5 (60 HZ AND 50 HZ MOTOR OPERATION AND DRIVE OUTPUT FREQUENCY): Both jumpers must be set for the appropriate motor nameplate frequency rating.

60 Hz and 50 Hz Motor Operation: The drive is factory set to operate 60 Hz motors. J4 is factory set to the "1X" position and J5 is factory set to the "60Hz" position. For 50 Hz motors, set J5 to the "50Hz" position, and J4 to the "1X" position.

Two Times Rated Motor RPM: The drive can operate motors up to two times the rated RPM. However, constant horsepower will result when operating the drive in the "2X" mode above the motor rated frequency. For 120 Hz output with 60 Hz motor, set J4 to the "2X" position and J5 to the "60Hz" position. For 100 Hz output with 50 Hz motor, set J4 to the "2X" position and J5 to the "50Hz" position.

60 Hz Motor Operation (Factory Setting)		50 Hz Motor Operation		120 Hz Motor Operation		100 Hz Motor Operation	
J4	1X	J4	1X	J4	1X	J4	1X
J5	60Hz	J5	60Hz	J5	60Hz	J5	60Hz
	2X		50Hz		2X		2X

J6 (BOOST MODE): J6 is factory set to the "FIX" position for Fixed Boost. For Adjustable Boost using the BOOST Trimpt, set J6 to the "ADJ" position.

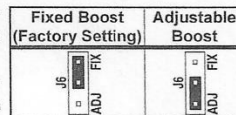

J7 (BRAKING MODE): J7 is factory set to the "RG" position for Regenerative Braking. For DC Injection Braking, set J7 to the "INJ" position. When the Injection Brake Mode is selected, the DECEL Trimpt is used to set the amount of time the DC current is applied to the motor.

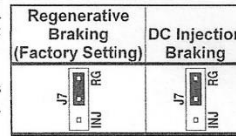

J8 (RUN/FAULT RELAY OPERATION): J8 is factory set to the "R" position for "Run" operation. For "Fault" operation, set J8 to the "F" position.

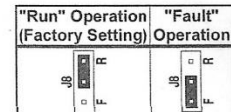

J9 (STOP CONTACT): J9 is factory set to the "NO" position for a normally open stop contact. For remote normally closed stop contact, set J9 to the "NC" position.

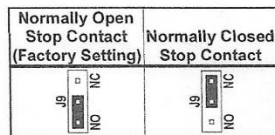

J10 (TORQUE MODE): J10 is factory set to the "CT" position for Constant Torque Mode, which is desirable for most machine applications. For Variable Torque Mode, used for HVAC and fan applications, set J10 to the "VT" position.

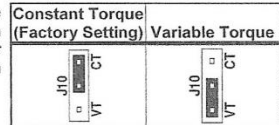

J11: Not used.

J12 (SWITCHING FREQUENCY AND GFCI) (Third Generation (3G) Models Only): J12 is set to the "8K" position for a switching frequency at the motor of 8 kHz. For 12 kHz switching frequency, set J12 to the "12K" position. This jumper also allows the drive to be used on standard ("G1"/"GF1" position) or sensitive ("G2"/"GF2" position) GFCIs. **Note:** GFCI operation may increase audible noise.

Third Generation (3G) Models	
8K	8 kHz Switching Frequency*
12K	12 kHz Switching Frequency
G1	Standard GFCI
G2	Sensitive GFCI
E	Not Used

KBAC-217, 416 Series	
<input type="checkbox"/> GF2	Sensitive GFCI
<input type="checkbox"/> GF1	Standard GFCI
<input type="checkbox"/> 12K	12 kHz Switching Frequency
<input checked="" type="checkbox"/> 8K	8 kHz Switching Frequency*

*Factory setting.

*Factory setting.

6 - OPTIONAL ACCESSORIES

See the KBAC Series Installation and Operation Manual for a complete list and description of optional accessories that are available.

To Validate the 18 Month Warranty, Register this Product Online

KBelectronics.com/registration.htm

HIGH VOLTAGE DIELECTRIC WITHSTAND TEST (HI-POT TEST)

WARNING! Disconnect all AC power before performing hi-pot test.

Testing agencies such as UL, CSA, etc., usually require that equipment undergo a Hi-Pot Test. In order to prevent catastrophic damage to the control, which has been installed in the equipment, it is recommended that the procedure outlined in the Installation and Operation Manual (viewable online and downloadable) be followed.

Do not exceed 1500 VAC for 115 VAC controls.
Control damage may result if hi-pot voltage is exceeded.

Note: Controls have been factory hi-pot tested in accordance with UL508C Standard.

CE INFORMATION

This product complies with all CE directives pertinent at the time of manufacture. Contact our Sales Department for Declaration of Conformity. Installation of a CE approved RFI filter is required. Additional shielded cable and/or AC Line cables may be required.

Note: To meet CE requirements, a separate CE approved filter must be installed.

UL NOTICE

230 Volt Drives: Suitable for use on a circuit capable of delivering not more than 5 kA RMS symmetrical Amperes. 230 Volts maximum. Use copper conductors rated 75 °C. Suitable for operation in a maximum surrounding air temperature of 40 °C.

460 Volt Drives: Suitable for use on a circuit capable of delivering not more than 5 kA RMS symmetrical Amperes. 460 Volts maximum. Use copper conductors rated 75 °C. Suitable for operation in a maximum surrounding air temperature of 40 °C.

SAFETY WARNING! - PLEASE READ CAREFULLY!

This product must be installed and serviced by a qualified technician, electrician, or electrical maintenance person familiar with its operation and the hazards involved. Proper installation, which includes electrical connections, fusing or other current protection, and grounding, can reduce the chance of electrical shocks, and/or fires, in this product or products used with this product, such as electric motors, switches, coils, solenoids, and/or relays. Do not use this drive in an explosion-proof application. Eye protection must be worn and insulated adjustment tools must be used when working with drive under power. This product is constructed of materials (plastics, metals, carbon, silicon, etc.) which may be a potential hazard. Proper shielding, grounding, and filtering of this product can reduce the emission of radio frequency interference (RFI) which may adversely affect sensitive electronic equipment. It is the responsibility of the equipment manufacturer and individual installer to supply this Safety Warning to the ultimate end user of this product. (SW 8/2012)

The control contains electronic Start/Stop circuits, which can be used to start and stop the control. However, these circuits are never to be used as safety disconnects since they are not fail-safe. Disconnect the input power for this purpose. Be sure to read and follow all instructions carefully. Fire and/or electrocution can result due to improper use of this product.

The information contained in these instructions is intended to be accurate.

However, the manufacturer retains the right to make changes in design which may not be included herein.



KB Electronics, Inc.
12095 NW 39th Street, Coral Springs, FL 33065-2516
Phone: (954) 346-4900 • Fax: (954) 346-3377
Call Toll Free: (800) 221-6570
E-Mail: info@kbelectronics.com • Website: www.kbelectronics.com

COPYRIGHT © 2018 KB Electronics, Inc.
(A40810) - Rev. B00 - 1/24/2018

Jumper Settings are continued at the top right column of this page.



Limited Warranty

The manufacturer warrants this equipment to the original user against material or workmanship for a period of 30 days from the date of purchase on repair parts and labor. The manufacturer's responsibility under this warranty is limited to the repair or replacement of defective part or parts. The manufacturer reserves the right to determine whether the part or parts failed because of material, workmanship, or other causes. Failure caused by accident, alteration, or misuse is not covered by this warranty.

A DALHART R&R MACHINE WORKS, INC. representative must perform all warranty repairs. Any repair to the equipment other than by this authorized facility voids this warranty. The rights under this warranty are limited to the original user and may not be transferred to subsequent owners.

The warranty is in lieu of all other warranties, expressed or implied, including warranties for a specific purpose.



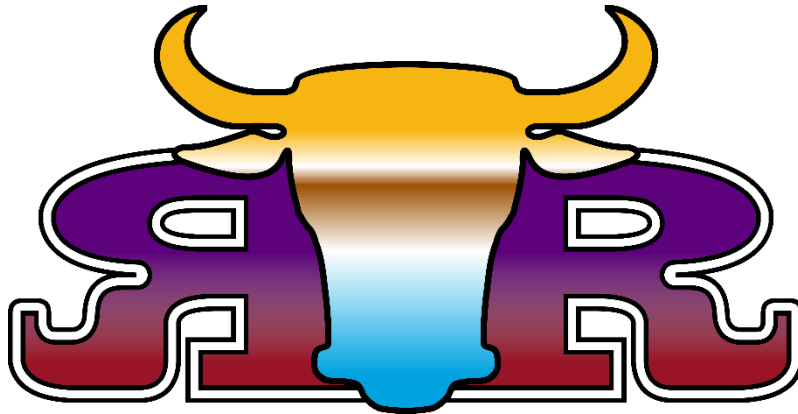

**Grain Cleaner
Operator's Manual
and Parts Guide**

Corporate Office:
P.O. Box 1330
1006 Liberal Street
Dalhart, TX 79022

Phone: (806) 244-5686
Fax: (806) 244-6096

www.r-rmachine.com
sales@r-rmachine.com